

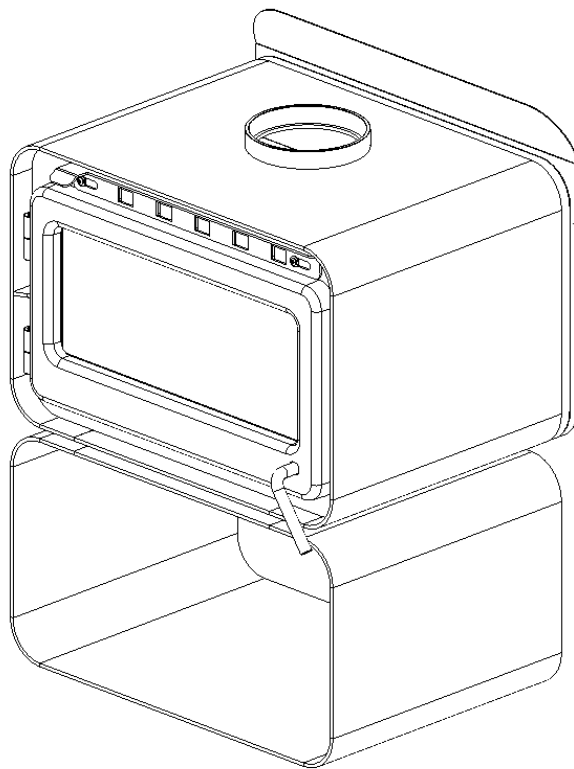

# Installation Instructions

*Contemporary and Stylish*



**B100**

**Keep instructions for future reference**



Glen Dimplex Australia proudly supports the activities of Landcare Australia through its membership of the AHHA

## TABLE OF CONTENTS

1.0	IMPORTANT INFORMATION .....	2
2.0	ASSEMBLING THE HEATER .....	3
3.0	INSTALLING THE HEATER .....	3
4.0	REDUCING CLEARANCES TO COMBUSTIBLES ...	4
5.0	INSTALLING THE FLUE .....	5
6.0	INSTALLING THE BAFFLE PLATE .....	6
7.0	INSTALLING THE FIREBRICKS .....	6
8.0	TECHNICAL DRAWINGS .....	7

### THE INSTALLATION INSTRUCTIONS IN THIS MANUAL APPLY TO THE BLAZE B100.

THEY HAVE BEEN TESTED FOR EMISSIONS AND EFFICIENCY AND COMPLY ACCORDING TO AS/NZS 4012:2014 & AS/NZS 4013:2014.

## 1. IMPORTANT INFORMATION

Most building regulatory Authorities in Australia require any wood heater installation to comply with Installation Standard AS/NZS 2918:2018. Different states and councils may have varying regulations. Check local building regulations before installing the appliance.

All Blaze wood heaters have been tested to ensure that they will meet the appropriate safety Standard requirements if the instructions in this manual are followed. As the safety and emissions performance can be affected by altering the appliance, no modifications are allowed without written permission from the manufacturer.

**WE RECOMMEND THAT THE INSTALLATION OF YOUR BLAZE WOOD HEATER BE CARRIED OUT BY A QUALIFIED INSTALLER.**

**WARNING: THE APPLIANCE AND FLUE SYSTEM SHALL BE INSTALLED IN ACCORDANCE WITH AS/NZS 2918:2018 AND THE APPROPRIATE REQUIREMENTS OF THE RELEVANT BUILDING CODE OR CODES.**

**WARNING: APPLIANCES INSTALLED IN ACCORDANCE WITH THIS STANDARD SHALL COMPLY WITH THE REQUIREMENTS OF AS/NZS 4012 & AS/NZS 4013 WHERE REQUIRED BY THE REGULATORY AUTHORITY, I.E. THE APPLIANCE SHALL BE IDENTIFIABLE BY A COMPLIANCE PLATE WITH THE MARKING 'TESTED TO AS/NZS 4012 & AS/NZS 4013'.**

**ANY MODIFICATION OF THE APPLIANCE THAT HAS NOT BEEN APPROVED IN WRITING BY THE TESTING AUTHORITY IS CONSIDERED TO BE IN BREACH OF THE APPROVAL GRANTED FOR COMPLIANCE WITH AS/NZS 4012 & AS/NZS 4013.**

**CAUTION: MIXING OF APPLIANCE OR FLUE-SYSTEM COMPONENTS FROM DIFFERENT SOURCES OR MODIFYING THE DIMENSIONAL SPECIFICATION OF COMPONENTS MAY RESULT IN HAZARDOUS CONDITIONS. WHERE SUCH ACTION IS CONSIDERED, THE MANUFACTURER SHOULD BE CONSULTED IN THE FIRST INSTANCE.**

**CAUTION: CRACKED AND BROKEN COMPONENTS, EG. GLASS PANELS OR CERAMIC TILES, MAY RENDER THE INSTALLATION UNSAFE.**

## 2. ASSEMBLING THE HEATER

This Blaze B100 heater will arrive with the firebox body secured to the wood box.

### Baffle Plate

To install the baffle plate, refer to section “6. *Installing The Baffle Plate*” for details.

### Bricks & Brick Retainers

To install the bricks and brick retainers, refer to section “7. *Installing The Fire Bricks*” for details.

### Ash Plate

The ash plate will arrive assembled. To replace the ash plate, refer to section “2. *Replacement of Ash Plate*” in the *Operating Instructions* for details.

## 3. INSTALLING THE HEATER

### 3.1 Positioning the Heater

First review the necessary **minimum** clearances specified below before considering where to position the heater. These clearances can be greater if desired.

Also check the practicability of installing the flue system in relation to any obstructing roof beams before positioning the heater.

These clearance distances can only be reduced if the surrounding walls are made of non-combustible material, e.g. Stone, brick, or concrete. If non-combustible material, distance can be reduced to 100mm. Alternatively, shielding of the wall(s) can reduce clearances (refer to next section for more detail).

Depending on the type of flue shielding used, the clearances to combustible surfaces varies.

#### 3.1.1 Standard Installation

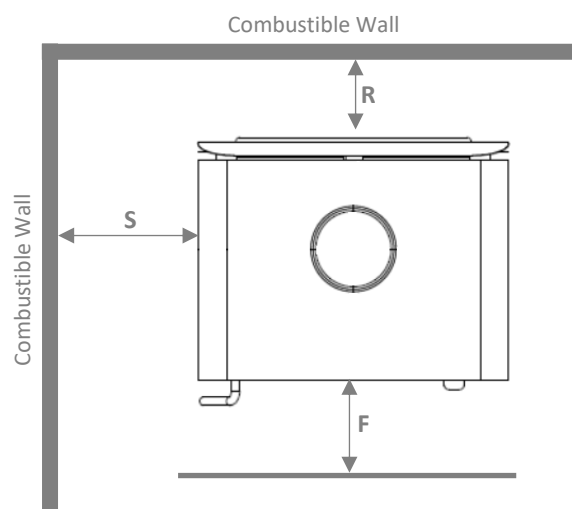

Standard Installation - minimum clearances

Model	Side	Rear	Front
Rear flue shield	700	200	300
Decromesh / solid flue shield	600	225	300

\*Decro-mesh & solid flue shield installation requires a 450mm inner reflector

### 3.1.2 Corner Installation

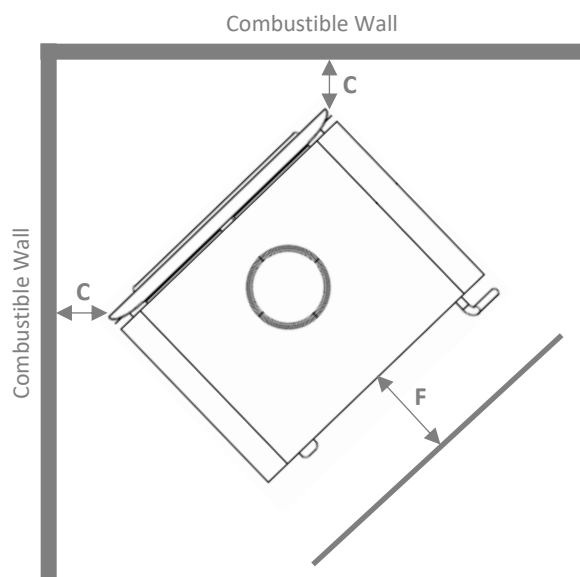

Corner Installation - minimum clearances

Model	Corner	Front
Rear flue shield	400	300
Decromesh / solid flue shield	400	300

\* Decro-mesh & solid flue shield installation requires a 450mm inner reflector

### 3.2 Floor Protector

Unless the heater will be standing on a heat resistant floor such as concrete slab with slate or tiles, it will be necessary to provide a floor protector.

The dimensions given above (Section 3.1) are the minimum required for the floor protector to extend beyond the firebox door opening. It must extend no less than 300 mm in front of the door opening, no less than 200mm either side of the door opening, and extend under the heater.

It may be desirable, for example aesthetic reasons, for the floor protector to be larger than these minimum dimensions.

The floor protector must be constructed of non-combustible material no less than 7.5mm thick and with a thermal conductivity not greater than 0.33W/m °K, e.g. compressed cement sheet.

The floor protector may be laid directly on the combustible floor.

For more details and variations on floor protectors refer to AS/NZS 2918:2018 Clause 2.2, 3.3.1, & 3.3.2.

## 4. REDUCING CLEARANCES TO COMBUSTIBLES

If it is necessary to install a heater closer to a combustible surface than the stated requirements in Section 3 of this Installation Guide, it must be done in accordance with Australian Standard AS/NZS 2918:2018 Section 3, Tables 3.1 & 3.2.

**Shield Construction:** The shield shall be constructed from a heat resistant material. The shield must be fixed to the surface that requires protection and NOT the heater.

The Standard allows three options to reduce stated clearances.

Single layer of continuous material with Minimum Air Gap of 12mm—Clearance Factor = 0.40

Single layer of continuous material with Minimum Air Gap of 25mm—Clearance Factor = 0.30

Two spaced layers of continuous material with Minimum Air Gaps of 12mm + 12mm—Clearance Factor = 0.20

The shielding must be open at the top and bottom (vented) to allow a continuous air flow. It is this air flow that keeps the surface requiring protection cool. Fixings should not impede this air flow.

The shielding needs to go far enough along and up the wall so that the original side and rear required clearances are not compromised. As the flue is now closer to the wall the shielding should also protect the wall from the flue pipe.

#### For example:

Side wall clearance for the B100 is 700mm.

A 12mm gapped shield on the wall with a factor of 0.40.

Calculate: - 700mm x 0.40 = 280mm. This is the new side wall minimum clearance.

The shielding needs to be large enough so that none of the original clearances of 700mm are compromised.

## 5. INSTALLING THE FLUE

The flue system used when installing the heater MUST comply with the current installation standard AS/NZS 2918.

Full instructions on the installation of the flue will be supplied with the flue kit. These MUST be followed closely, including the minimum exit height from the top of the floor protector being not less than 4.6m, and the minimum exit height above the roof line of roof ridge as detailed in the instructions.

The flue must be fitted with one of the following:

1) **Rear flue shield** – 900 mm long, minimum 160° arc, stainless steel rear flue shield with 25mm gap between it and the 150mm diameter active flue, and 25mm above the top of the heater, OR

2) **Decro-mesh / Solid Flue Shield:** -

**Note: MUST be installed with the manufacturer's 450mm tall inner flue shield AND ventilated decro-mesh locating ring.**

- A full length, half radius perforated decro-mesh flue shield extending from the heater through into the drop box penetrating the ceiling with the perforated surface facing the front, OR equivalent in solid outer flue shield casing (7.75" diameter)
- The 450 mm half round stainless steel inner reflector supplied with heater must be fitted inside the decro-mesh or solid outer flue shield.
- **The manufacturer's decro-mesh 'locating ring' must be used to support the decro-mesh and inner shield up off the heater top.** It is important that air can be drawn into the base and rear of the flue shielding.
- Place the locating ring above the flue spigot (resting on the top plate) and then place the first length of 150mm active flue into the spigot. With the 450mm inner shield fitted inside the decro-mesh or solid outer shield, slide the shielding over the active flue. Locate the bottom of the decromesh or solid outer shield and inner shield inside the locating ring.

Decromesh / solid outer flue shield  
Stainless steel inner flue shield  
inside thereof of decro-mesh  
or solid outer flue shield

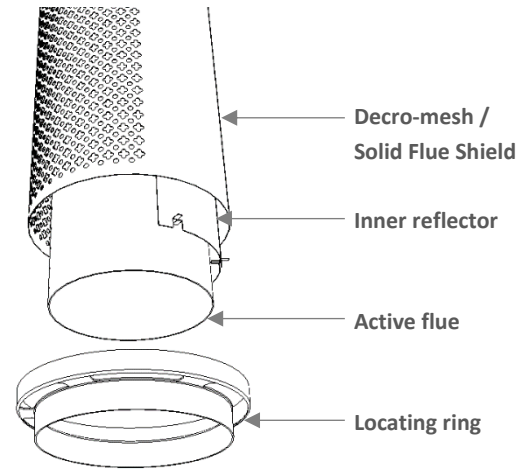

- Depending on the supplier, the flue shielding can be one of three sizes – 200 mm, 7 ¾ inch, or 8 inch diameter. The decro-mesh ring will fit the two smaller diameters but not the 8 inch. In this scenario, snip through the outer ring with tin-snips as shown in the drawing below. Bend the two "arms" in a little so they ends don't project out when fitted to the decro-mesh. Ensure that the snipped section is at the rear of the flue, out of sight.

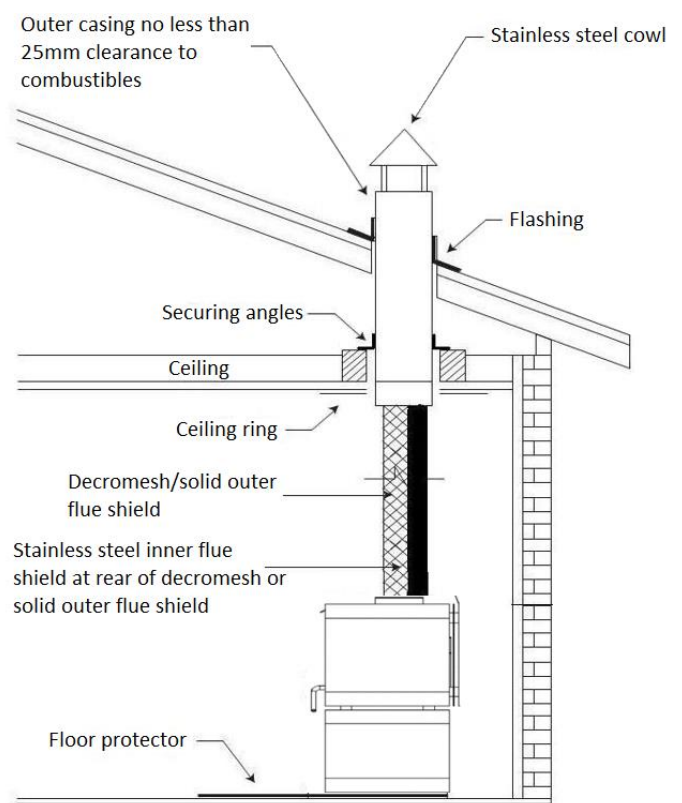
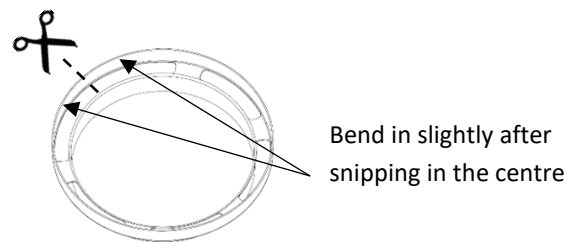

If the draft is insufficient or periodic down drafting occurs and the heater smokes or only burns slowly, extending the flue or fitting a specialist cowl will usually resolve the issue.

### Fitting Flue Seal

Any gaps between the inside of the flue spigot and the 6 inch active flue should be sealed. This can be done by wrapping the bottom of the flue with the piece of adhesive backed high temperature cloth tape supplied. Alternatively, stove cement designed for this purpose can also be used.

## 6. INSTALLING THE BAFFLE PLATE

The baffle plate should be installed before installing the fire bricks.

- 1) Place the baffle inside the firebox with the trapezium fold directed upwards and at the front of the firebox. (refer to following diagram for correct orientation).
- 2) Raise the front of the baffle, tilting it back so that it clears and rests on the front support rods.
- 3) Raise the rear of the baffle, bringing it forward enough to clear the rear support rods.
- 4) Once clear of the rear support rods, push the baffle back so that it is resting hard up against the rear of the firebox.
- 5) Centralise the baffle so that gaps between each side and firebox are equal.

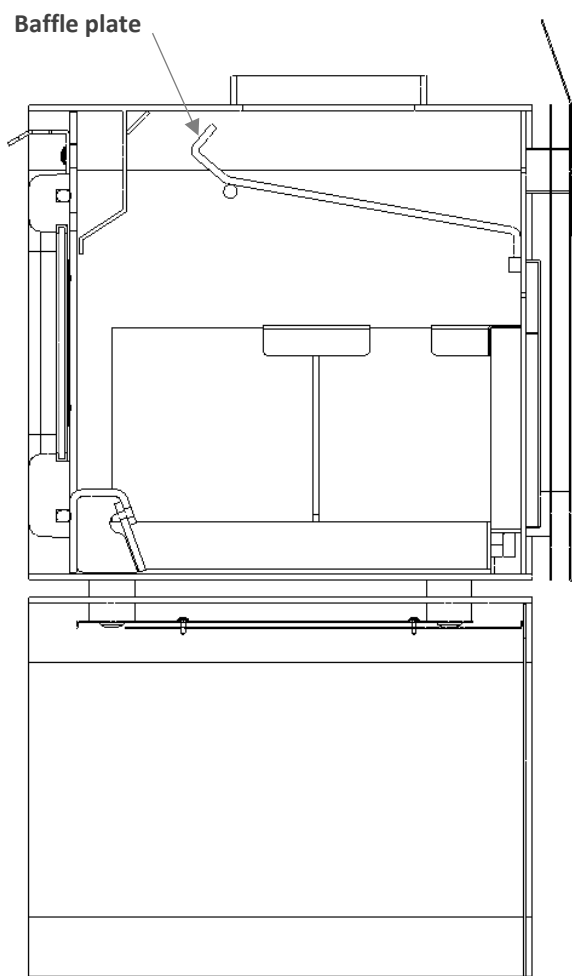

## 7. INSTALLING THE FIRE BRICKS

- 1) Place lower brick retainers in base of firebox, centralised and against rear of the firebox.
- 2) Place three bricks along the back.
- 3) Place two medium size bricks along each side.
- 4) Place upper brick retainers on top to hold the bricks upright and in place.

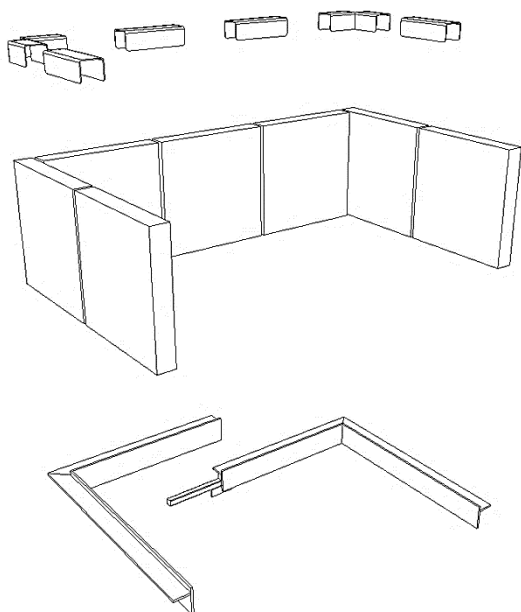

## 8. TECHNICAL DRAWINGS

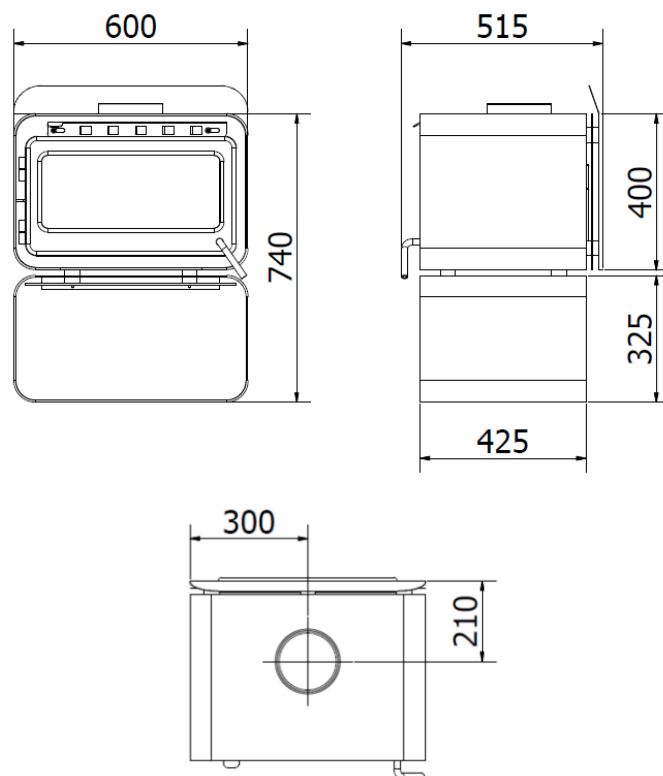



Glen Dimplex Australia Pty Ltd

8 Lakeview Drive,  
Scoresby Victoria 3179  
Australia

T: 1300 556 816 | F: 1800 058 900

Email: [sales@glendimplex.com.au](mailto:sales@glendimplex.com.au)

---